

GENERAL NOTES:

- 1) GRAY FRP INTERIOR & EXTERIOR WALL SURFACE.
- 2) ALUMINUM FRAMING EXTRUSIONS HAVE A MILL FINISH.
- 3) ALL WINDOWS, INCLUDING DOORS HAVE CLEAR TEMPERED GLASS.
- 4) UNIT INCLUDES FACTORY INSTALLED INTEGRAL ROOF.
- 5) INTERIOR CLEAR HEIGHT (FLOOR-TO-CEILING) IS 82 5/8".
- 6) OVERALL EXTERIOR HEIGHT IS 91".
- 7) FINISHED FLOORING TO BE VINYL TILE.
- 8) THE 2x4 SUPPORT BOARDS ATTACHED TO THE UNDERSIDE OF THE BLDG. ARE USED FOR SHIPPING PURPOSES ONLY AND NEED TO BE REMOVED AT INSTALLATION.

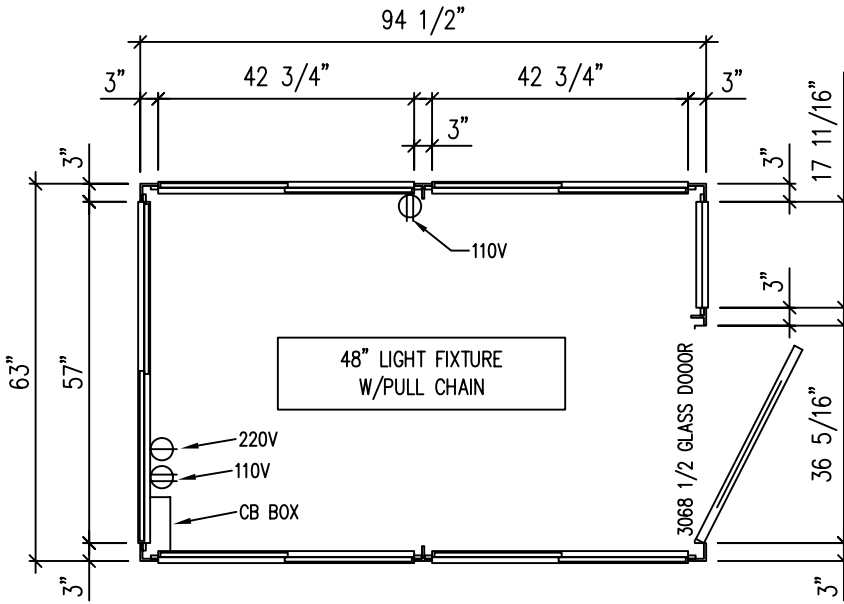

FLOOR PLAN

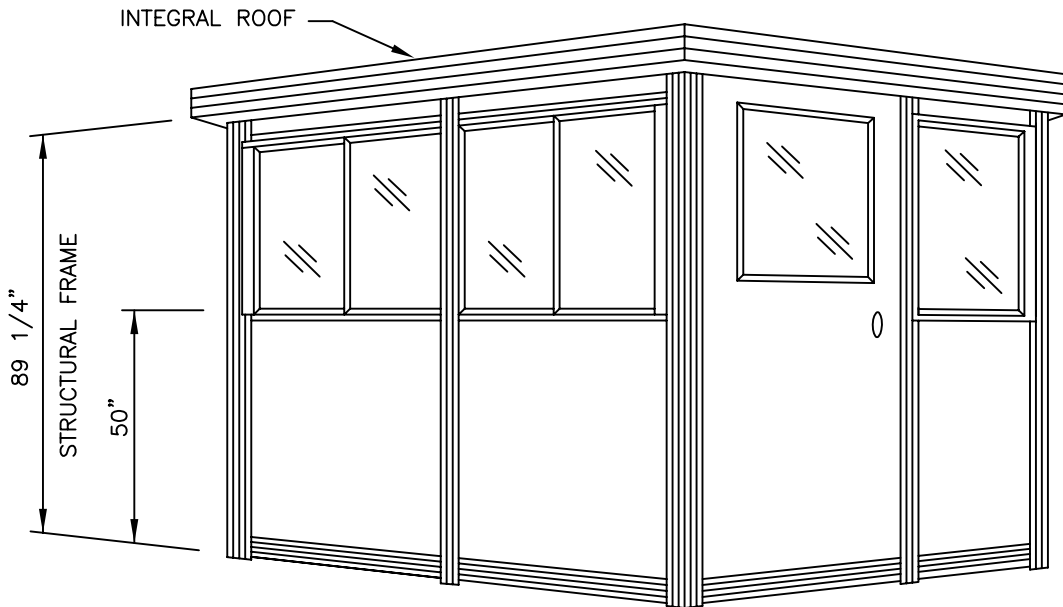

MODEL 58

MODEL 58

PRE ASSEMBLED

PORTA-FAB CORPORATION

P.O. BOX 1084 CHESTERFIELD, MO. 63006-1084

JOB: 01PA10

SCALE

N/A

DATE

These documents were developed by PORTA-FAB Corporation. The contents of these documents are the proprietary property of PORTA-FAB Corporation. They are not to be copied or otherwise used without the express written permission of PORTA-FAB Corporation. Copyright 2003 PORTA-FAB Corp.

DRAWN BY

SLC

REVISED

CHECKED

SHEET NO. 1 OF 1