

# Modular Offices & Inplant Buildings



**PORTAFAB**  
Modular Building Systems



# Construction Simplified.

## PORTAFAB MODULAR CONSTRUCTION

VS.

## CONVENTIONAL CONSTRUCTION

PortaFab Modular Building Systems simplify the construction process. Our pre-engineered systems are not only designed to be installed more quickly, easily and inexpensively than traditional construction, but they are also more flexible and environmentally friendly.



## TOP 10 Reasons to Consider PortaFab Modular Building Systems

1

### Versatility

Easily expand, relocate or reuse to keep up with your expanding business.

2

### Quick Installation

Pre-engineered systems minimize installation time.

3

### Reduced Construction Labor Costs

Simple installation yields lower costs.

4

### Reduced Design Time

Limited engineering and architectural time required.

5

### Ease of Coordination

Single source installation through a factory-trained distributor network.

6

### Clean Installation

Minimal on-site construction and fabrication.

7

### Low Maintenance

Durable wall panels require only occasional surface cleaning.

8

### Consistent Quality & Appearance

Complete design consistency throughout.

9

### Tax Advantages

Depreciate over 7-½ years versus 39 years.

10

### Environmentally Friendly

Less construction waste and more LEED points.

*Even large inplant buildings are simplified with PortaFab modular building systems*

# PORTAFAB The Industry Leader

As pioneers in the field, PortaFab has established itself as the industry leader by developing the largest line of high quality modular building systems backed by an experienced team and nationwide network of certified dealers.

## Unmatched Selection

With the most extensive product line in the industry, PortaFab can mix and match various components from its line of inplant office systems, XTRA TALL wall systems, and cleanroom systems to ensure that your space is designed and manufactured in the most cost-effective manner.

## Certified Quality

PortaFab quality management systems are certified to ISO 9001:2015 with a focus on continuous quality improvement.



## Expert Design & Engineering

Architects, contractors, and end customers benefit from our decades of design and engineering experience. We are experts in the design of modular offices, cleanrooms and controlled environments.

## Proven Experience

Since 1980, PortaFab has played an active role in the creation of millions of square feet of enclosed spaces throughout the world.



## Certified Dealer Network

Locally sourced installation through our extensive network of experienced dealers.

## Table of Contents

<b>Standard Quick-Ship Units</b> .....	4
<b>Modular Offices and Buildings</b> .....	6
<b>Framing Systems</b>	
<b>OmniFlex</b> .....	8
<b>Series 300</b> .....	10
<b>PortaMax Series</b> .....	12
<b>Wall Panels</b> .....	14
<b>SteelSpan</b> .....	15
<b>Windows</b> .....	16
<b>Doors</b> .....	17
<b>Roof &amp; Ceiling</b> .....	18
<b>Electrical &amp; Climate Control</b> .....	19
<b>Applications Photo Gallery</b> .....	20-31
<b>Additional Capabilities</b> .....	Back



# Standard “Quick-Ship” Units

## 5-Day “Quick-Ship” Program

Our integrated modular systems design and interchangeability of parts enables us to ship most standard in-plant office orders within 5 days. “Quick-Ship” units come as two, three, or four wall buildings created from the OmniFlex steel framing system.



## Components

“Quick-Ship” units can include the components listed on page 5.

## 30 Standard Sizes

PortaFab’s “Quick-Ship” modular units come as two, three, or four wall buildings with 30 different sizing options to choose from.



*Standard “Quick-Ship” models allow for speedy delivery & installation.*

Standard Sizes				
8 x 8	10 x 10	12 x 12	16 x 16	20 x 20
8 x 10	10 x 12	12 x 16	16 x 20	20 x 24
8 x 12	10 x 16	12 x 20	16 x 24	20 x 28
8 x 16	10 x 20	12 x 24	16 x 28	20 x 32
8 x 20	10 x 24	12 x 28	16 x 32	20 x 36
8 x 24	10 x 28	12 x 32	16 x 40	20 x 40

Qualifying Options	Non-Qualifying Options
8' or 9' wall height	Special cut height
Gray or white finish both sides	Any other color
Fire and sound (F&S) Panels with 1/2" vinyl gypsum on polystyrene core	Other panel construction
3070 & 6070 doors with or without glass	Other door sizes
1/4" clear tempered glass, 4' x 3' or 2' x 3' fixed windows	Other glass options
Framed A/C cutouts	Large cutouts and openings
Dust cover support beam	Load-bearing roofs
Buildings 20' wide or less	Buildings wider than 20'



# Anatomy of a Quick-Ship Unit

PortaFab Quick-Ship units are available with a number of standard features and can be configured with multiple options for your specific needs.

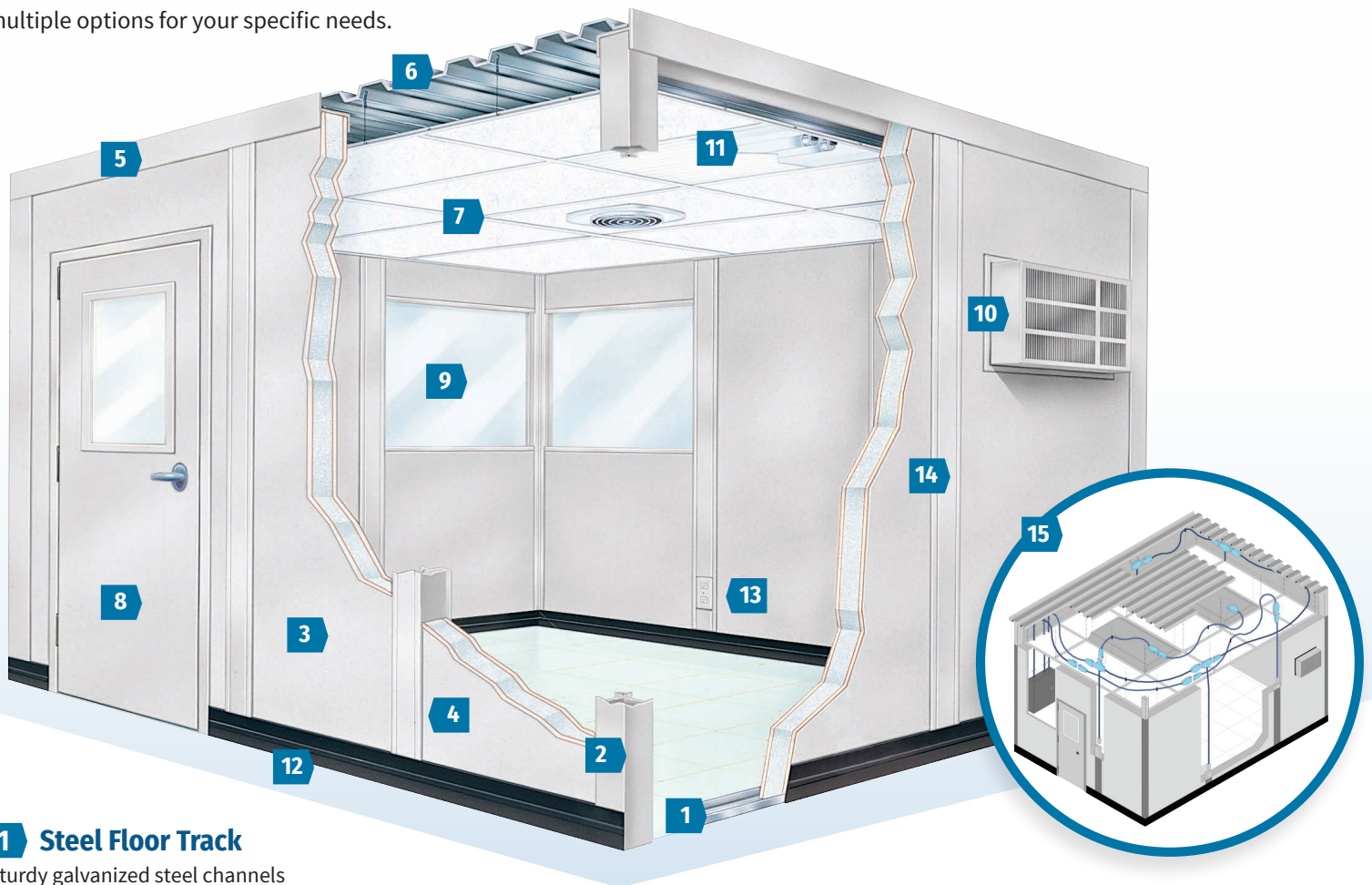

## 1 Steel Floor Track

Sturdy galvanized steel channels hold wall panels securely in place.

## 2 Corner Post

Structural, non-progressive 3-piece design.

## 3 Fire & Sound Panels

Includes 1/2" thick vinyl gypsum surface bonded to both sides of polystyrene insulating core.

## 4 Structural Stud System

Multi-piece stud construction allows for non-progressive system.

## 5 Cornice Mold

Sturdy aluminum construction, painted; provides handsome finished appearance.

## 6 Roof Deck

22 gauge ribbed steel is 1-1/2" deep; painted and cut to length up to 12'. Support beams/angles available for larger units.

## 7 Acoustical Lay-in Ceiling

Pre-painted, wire-hung metal grid with lay-in acoustical ceiling tiles made from noncombustible white fissured mineral board.

## 8 Door

1-3/4" thick, 20 gauge steel door. Pre-hung in frame with flush finish. Available with single or double doors with or without 1/4" clear tempered safety glass.

## 9 Windows

Comes pre-glazed in aluminum window frame with 1/4" clear tempered safety glass measuring 4' x 3' or 2' x 3'.

## 10 AC/HVAC

Available with framed cutouts and AC/HVAC systems in several BTU capacities.

## 11 2' x 4' Light Fixture

4-lamp light fixture with acrylic lens.

## 12 Vinyl Base

Screw-on type base is easily removable with no exposed screws or fasteners.

## 13 Duplex Receptacle

Can be located in any wiring stud.

## 14 Electrical Integration

Permits the installation of electrical service vertically and accepts electrical boxes.

## 15 Modular Electric Package

Plug and Play connection for faster installation to include lights, outlets and switches.

# Pre-Engineered Solutions

## Complete Design Flexibility

In addition to our line of Standard “Quick Ship” Modular Offices, PortaFab offers pre-engineered systems that will allow you to transform and utilize your space more effectively. We offer the most extensive selection of framing systems, interchangeable wall panels, and accessories in the industry, providing you with complete flexibility and customization for your next project.

The flexibility inherent in PortaFab’s prefabricated components provides you with the freedom to design and equip your space for maximum utility and appearance at an affordable price.



### Wall Panels

With PortaFab’s “Post-and-Panel” design, each framing system can be outfitted with composite wall panels designed for applications ranging from simple inplant offices to sophisticated controlled environments.

#### Standard Colors

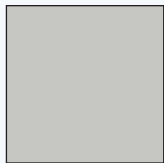

Gray



White

### Framing Systems

At the heart of every modular wall system lies the metal stud framing. Not only does this provide the structural integrity for the entire office or enclosure, but it also makes the system relocatable, attractive, and easy to assemble. With multiple framing systems and our SteelSpan “All-in-One” wall system, you can rest assured that PortaFab will have the right solution for your application.

### Modular Building Components

PortaFab’s engineered systems go a step-further with our innovative modular electrical package, multiple window options, standard or load-bearing roofs and the ability to integrate various doors, climate control options and more.

## System Comparison Guide

	OmniFlex	Series 300	PortaMax 458S	PortaMax 600S	PortaMax 458A	SteelSpan
Wall Thickness	3"	3"	4-5/8"	6"	4-5/8"	3 - 6"
Max Height*	18'	18'	24'	35'	23'	50'+
Load-bearing	Yes	Yes	Yes	Yes	Yes	No
Stud Design	2 piece Steel 2 cover plates	2 piece Aluminum 1 cover plate	3 piece Steel 2 cover plates	3 piece Steel 2 cover plates	2 piece Aluminum 1 cover plate	No stud required
Frame Finish	Gray or White	Anodized Aluminum or Painted*	Gray or White	Gray or White	Anodized Aluminum or Painted*	Baked Polyester

\*Series 300 and PortaMax 458A can be painted gray or white.



# Unlimited Configurations

PortaFab's modular building systems can be easily incorporated into a wide variety of designs to maximize space, minimize costs and provide nearly unlimited flexibility.

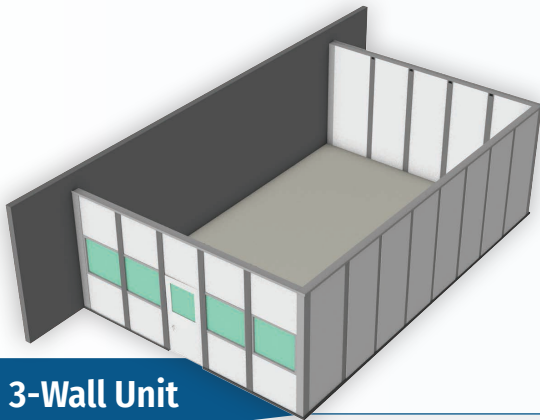

## 3-Wall Unit

3-wall units can attach to an existing wall to cut expenses, while also providing all of the flexibility you need.

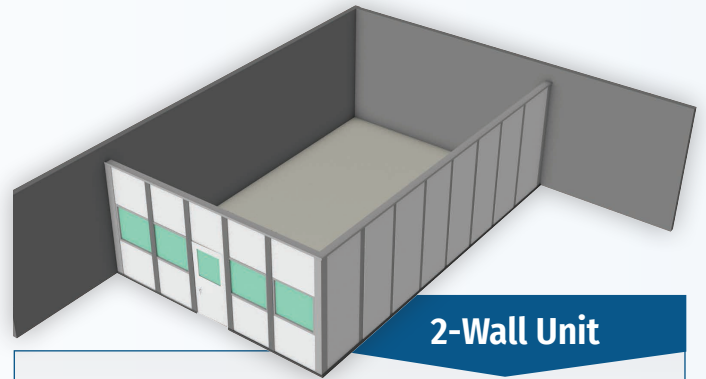

## 2-Wall Unit

2-wall units utilize existing corner walls to minimize costs, while also providing an effective work area at your facility.

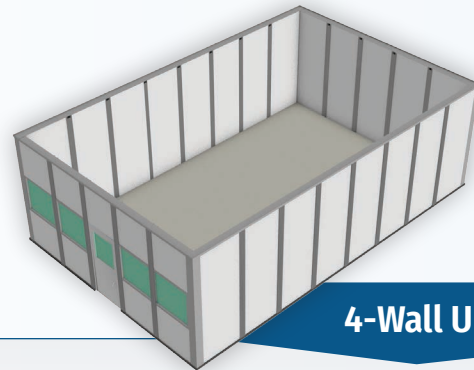

## 4-Wall Unit

Total flexibility is yours. Design one large work area, or subdivide into separate offices. It's up to you.



## Mezzanine Units

Mezzanine units provide maximum use of available floor space utilizing vertical plant space for office areas.

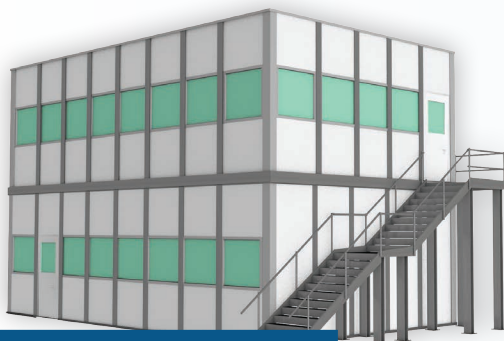

## Two-Story Office Units

Ideal for creating additional office space while minimizing the use of valuable plant floor space.



## Office with Storage Space

Ideally suited for maximizing office space in facilities with high ceilings, our OmniFlex and Series 300 framing systems support load-bearing roofs - without adding costly support columns or mezzanines.

## 3" Steel Framing System

The core of any modular building is its framing system and the OmniFlex leads the industry. Whether you need a simple supervisor's office or a two-story inplant building, OmniFlex modular wall systems offer a high quality, low cost solution. This versatile steel stud framing system utilizes 3' thick walls that support load-bearing roofs and two-story construction without the need for costly support columns. It is our most popular and best value 3" framing system.

*The OmniFlex system supports load-bearing roofs and two-story construction without adding costly support columns.*



### Modular Flexibility

With OmniFlex walls, whenever you change your plant layout, your modular building can change with it. Non progressive construction makes it easy to expand, modify, or relocate these units. So, you save time and money in the future, as well as on your initial modular building investment.

### Structural Integrity

With stud sections that physically connect back-to-back, OmniFlex provides the strongest load-bearing system on the market. The unique double layer steel studs provide more strength and the roll formed ends reduce tear risks during assembly.



**OMNIFLEX STUD CONSTRUCTION**  
*Solid construction of two-piece steel studs join together to make OmniFlex stronger than any comparable 3" system.*

### Professional Appearance

Color coordinated panels, studs, doors, and trim, bring a professional "front office" finish to OmniFlex in-plant buildings. Standard colors are gray and white with matching trim and wall panels for a smooth monochromatic finish. Optional colors can be ordered.



**WIRING STUDS**  
*Removable "snap-in" cover plate allows for wiring capabilities on both sides of the stud and easy inspection of raceway.*

### Excellent Value

OmniFlex modular buildings offer quality, appearance, and cost savings that make conventional construction obsolete. They are completely re-usable so your modular building can grow with your business. You save time and money in the future, as well as on your initial investment.





## Specifications

**Thickness:** 3" thick wall panels

**Heights:** Standard wall heights up to 18 feet

**Material & Finish:** Galvanized steel with baked enamel finish

**Colors:** Standard colors are gray and white

**Load-bearing:** Yes

## Component Integration

**Wall Panels:** Compatible with a variety of standard and custom wall panels.

**Windows:** 4 standard window styles with a variety of sizes and glazing options.

**Doors:** Capable of integration with standard, roll-up, sliding, and other doors.

**Electric:** Wiring raceway for easy integration of electrical voice and data. Modular electric systems also available.

**Climate Control:** Can be integrated with central HVAC systems, wall units or ductless systems.



## INPLANT OFFICES

*Modular offices with sound deadening wall panels keep production personnel out on the plant floor and close to the action while providing a clean, quiet environment in which to work.*

# Series 300

## 3" Aluminum Framing System

Our Series 300 wall system closely matches the performance features of our OmniFlex system but features an anodized or painted aluminum stud construction. The system is typically specified for use in cleanroom applications and spaces that need to comply with food safety standards or other industry guidelines.

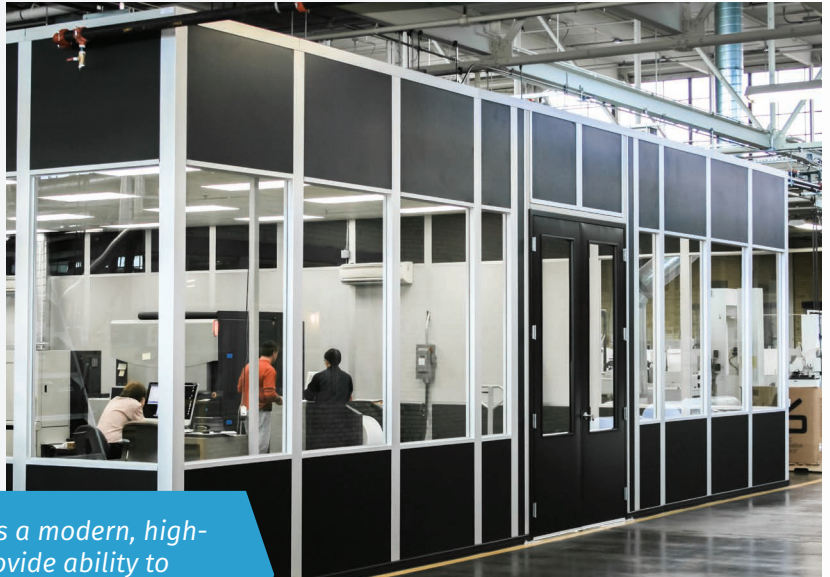

*The anodized aluminum framing system creates a modern, high-tech look while custom panel surface colors provide ability to meet both appearance and functional requirements of almost any plant environment.*



### WIRING STUDS

*Removable "snap-in" cover plate allows for wiring capabilities and easy inspection of raceway.*

### Modular Flexibility

Whenever you change your plant layout, your modular building can change with it. Nonprogressive construction makes it easy to expand, modify, or relocate these units. So, you save time and money in the future, as well as on your initial modular building investment.

### Structural Integrity

With stud sections that physically connect, Series 300 is one of the strongest load-bearing systems on the market. The patented aluminum studs provide strength.

### Professional Appearance

Color coordinated panels and doors can complement the anodized aluminum or painted framework to bring a professional "front office" finish to any inplant building. Standard colors include gray and white.

### Excellent Value

Series 300 modular buildings offer quality, appearance, and cost savings that make conventional construction obsolete. They are completely re-usable so your modular building can grow with your business. You save time and money in the future, as well as on your initial investment.

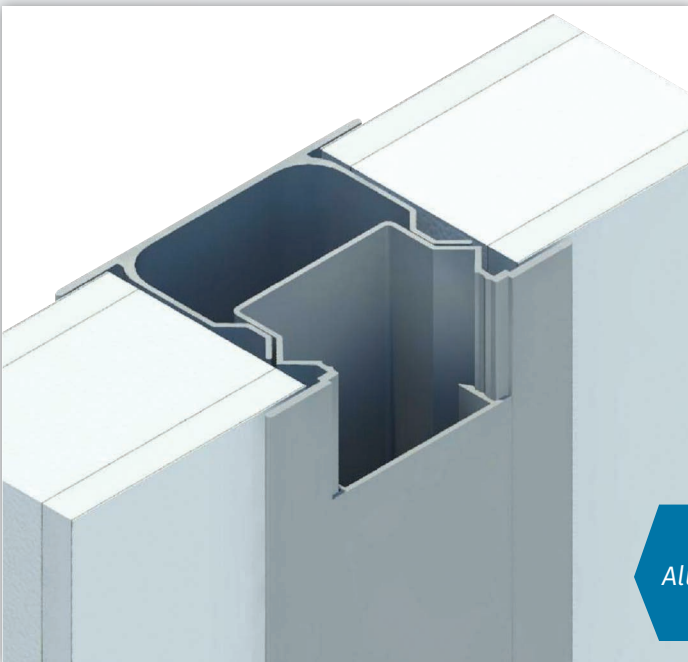

### SERIES 300 STUD CONSTRUCTION

*Aluminum stud construction with unique design that enables fast, easy assembly and provides quick access to wiring.*





## Specifications

**Thickness:** 3" thick wall panels

**Heights:** Standard wall heights up to 18 feet

**Material & Finish:** Anodized or painted aluminum

**Colors:** All studs are anodized or painted aluminum that can be paired with wall panels in white or gray. Custom colors available upon request.

**Load-bearing:** Yes

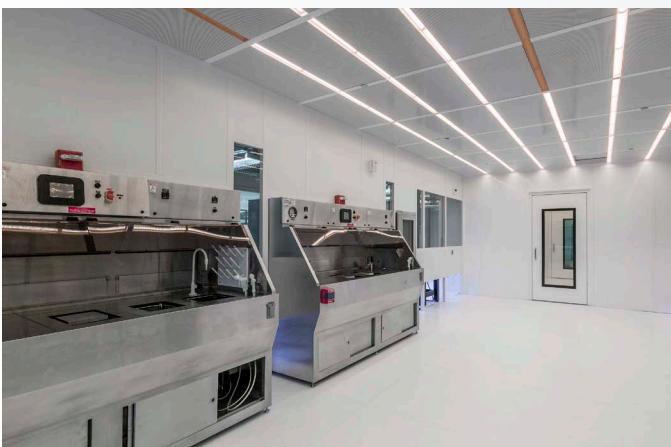

## CLEANROOMS

*The Series 300 wall system is often used for creating standalone units like this ISO 7 cleanroom for medical device manufacturing. The load-bearing roof supports HVAC equipment and provides easy maintenance access.*

## Component Integration

**Wall Panels:** Compatible with a variety of standard and custom wall panels.

**Windows:** 4 standard window styles with a variety of sizes and glazing options.

**Doors:** Capable of integration with standard, roll-up, sliding, and other doors.

**Electric:** Wiring raceway for easy integration of electrical voice and data. Modular electric systems also available.

**Climate Control:** Can be integrated with central HVAC systems, wall units or ductless systems.

## XTRA TALL Wall Framing System

With PortaMax tall modular walls, you can effectively divide your plant space from floor to roof or create free-standing in-plant buildings taller and stronger than ever before possible with modular construction. PortaMax gives you exactly the enclosed space you need to control dust, temperature, humidity, noise, and other environmental needs. PortaMax is moveable, reusable, and designed to connect to either an overhead steel structure or as a self-contained, free-standing structure with a roof deck.

### Modular Flexibility

Nonprogressive construction allows for the easy removal of individual panels without disturbing adjacent panels. Just remove necessary wall sections to move equipment into completed units and replace in a fraction of the time needed in a conventionally built facility. Customized designs meet your exact room needs enabling you to interface easily with process equipment and accommodate conveyor openings or pass-throughs. You save time and money in the future, as well as on your initial modular building investment.

### Wiring Studs

Removable “snap-in” cover plates allow for wiring capabilities and easy inspection of raceways without affecting the structural integrity of the stud.

### ALUMINUM FRAMING SYSTEM

- Ideal for clean areas
- 4-5/8" and 6" Thicknesses
- Extended heights and higher ceilings
- Large clear span and better insulation

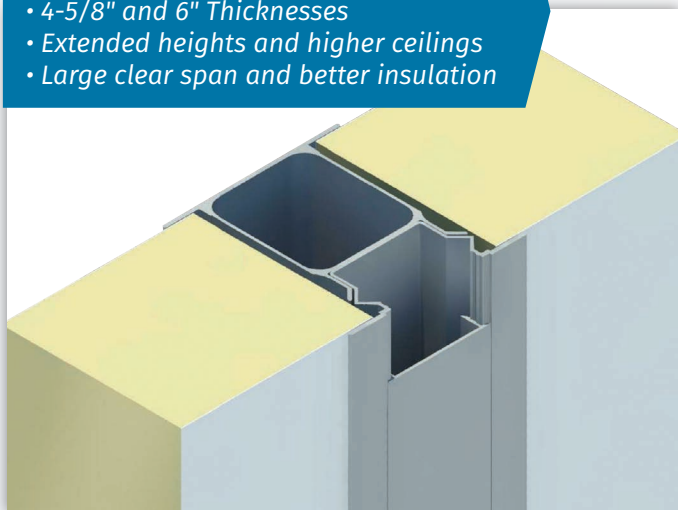

Demising Wall for Dust Containment

### STEEL FRAMING SYSTEM

- For industrial applications
- 4-5/8" and 6" Thicknesses
- Extended heights and higher ceilings
- Large clear span and better insulation

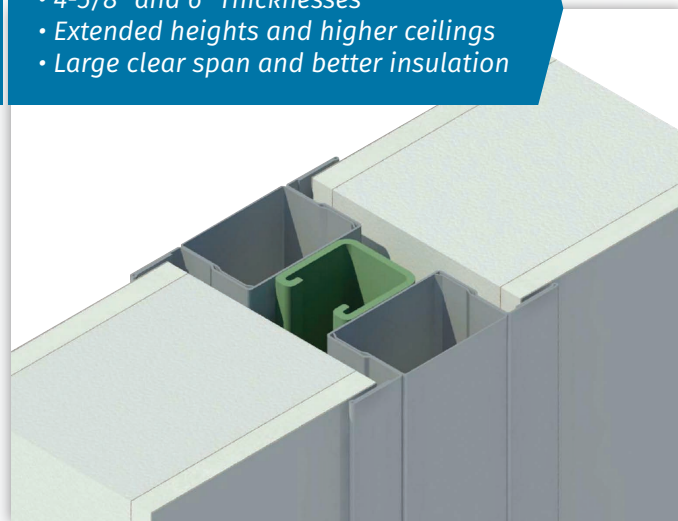

### Functionality

Increased wall heights allow you to create floor to roof systems or achieve specific clearance for machinery or ceiling plenums to conceal and house equipment. Wall panels feature a variety of core materials and panel finishes for meeting specific requirements for acoustic and thermal insulation, chemical resistance, and static control.

### Load-Bearing Roof Wall System

The PortaMax system is designed to support many types of roof loading. Design criteria can include man loads, 2-story, roof-mounted HVAC and duct work, and storage loads. Please consult factory for specific needs.





Quality Control Room with Integrated Interior Crane

### PortaMax Steel Specifications

**Thickness:** 4 $\frac{5}{8}$ " and 6"

**Heights:** 24' (4 $\frac{5}{8}$ ") and 35' (6")

**Material & Finish:** Galvanized steel with baked enamel finish

**Colors:** Standard colors are gray and white

**Load-bearing:** Yes

### PortaMax Aluminum Specifications

**Thickness:** 4 $\frac{5}{8}$ "

**Heights:** Up to 23'

**Material & Finish:** Anodized Aluminum

**Colors:** All studs are anodized aluminum that can be paired with wall panels in a wide variety of colors

**Load-bearing:** Yes

### Component Integration

**Wall Panels:** Compatible with a variety of standard and custom wall panels.

**Windows:** 2 standard window styles with a variety of sizes and glazing options.

**Doors:** Capable of integration with standard, roll-up, sliding, and other doors.

**Electric:** Wiring raceway for easy integration of electrical voice and data. Modular electric systems also available.

**Climate Control:** Can be integrated with HVAC systems or feature wall units, and ductless systems.

# Wall Panels

## Solutions for Every Application

With PortaFab's "Post-and-Panel" design, each framing system can be outfitted with composite wall panels designed for applications ranging from simple inplant offices to sophisticated controlled environments. Listed here are some of our standard and more popular wall panels, but custom panels can be designed and manufactured to meet your exact specifications.

### Fire & Sound

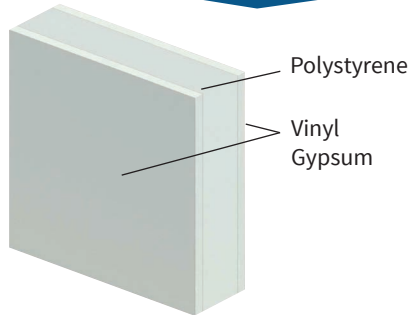

Panel Thickness	3"	4 <sup>5</sup> / <sub>8</sub> "
STC	31	31
R-Value	11	16

### Fire & Sound w/ Steel Exterior

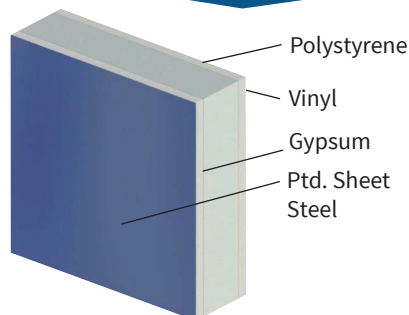

Panel Thickness	3"	4 <sup>5</sup> / <sub>8</sub> "
STC	31	31
R-Value	11	16

### Steel Fire & Sound

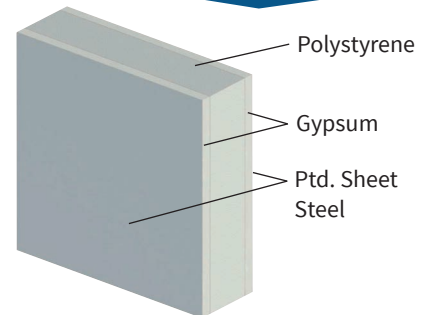

Panel Thickness	3"	4 <sup>5</sup> / <sub>8</sub> "
STC	32	31
R-Value	11	16

### FRP Thermal

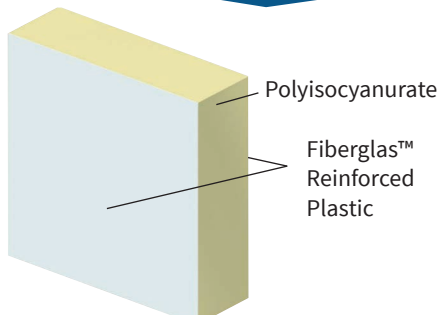

Panel Thickness	3"	4 <sup>5</sup> / <sub>8</sub> "
STC	24	24
R-Value	18	28

### Hollow Cavity

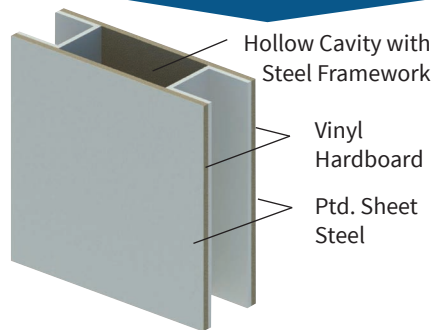

Panel Thickness	3"	4 <sup>5</sup> / <sub>8</sub> "
STC	20	20
R-Value	1	1

### Aluminum Honeycomb



Panel Thickness	3"	4 <sup>5</sup> / <sub>8</sub> "
STC	28	28
R-Value	1	1

### Steel Thermal

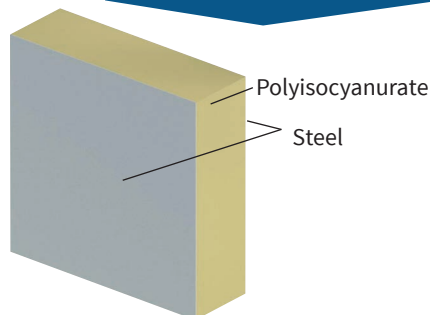

Panel Thickness	3"	4 <sup>5</sup> / <sub>8</sub> "
STC	24	24
R-Value	22	29

### Mineral Wool

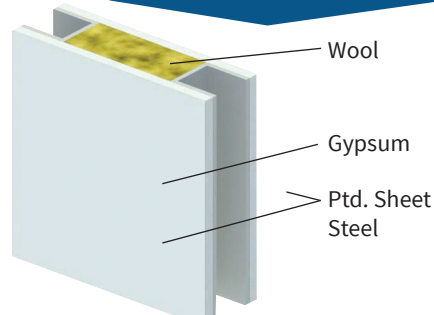

Panel Thickness	3"	4 <sup>5</sup> / <sub>8</sub> "
STC	42	42
R-Value	12	19

### Custom



Our team can also manufacture composite wall panels to meet your specific requirements.

- Unlimited Core Materials
- Unlimited Face Skins



## SteelSpan - The "All in One" Wall System

The SteelSpan "all in one" panel is an innovative modular wall system that does not require a framing system. Its innovative design is ideal for effectively and economically dividing your plant space from floor to roof or for creating ceilings and roofs in commercial and industrial buildings. The non-combustible panels are constructed of a polyurethane insulating core with excellent insulation values. SteelSpan panels are light weight, yet structurally strong and feature a one-piece construction that makes assembly quick and cost effective.



*SteelSpan is a functional and cost-effective solution for all types of industrial partition applications.*

### Complete Engineered Solutions

PortaFab provides the engineering and components needed to provide a complete engineered solution. Standard doors, windows, connectors and other framing components make integrating with existing ceilings, floors and walls seamless.

### Structural Integrity

Despite their light weight, SteelSpan Panels are structurally strong enough for greater heights. They range in thickness from 3" to 6" and are constructed of G-90 galvanized steel with a secure tongue and groove connection.

### Common Applications

- Manufacturing facilities
- Distribution warehouses
- Equipment screens
- Demising wall
- Cleanrooms
- Panelized ceilings

## Specifications

**Core:** Foamed-in place, Blister-Free, Non-CFC polyurethane, Factory Mutual Class 1 approval.

**Panel Thickness:** 3", 4", 5" or 6"

**Heights:** 8'to 50'+

**Material & Finish:** Corrugated profile, Stucco embossed G-90 galvanized steel (26, 24 and 22 Gauge) with baked polyester finish. Optional finishes available.

**Colors:** Standard colors are gray and white. Optional colors are available.

Panel	3"	4"	5"	6"
STC	24	24	24	24
R-Value	22	29	36	43



### STEEL EXTERIOR, FOAM CORE

*The non-combustible panels are constructed of a polyurethane insulating core laminated between stucco embossed galvanized sheet steel. A lightly corrugated profile on both faces of the panel ensures symmetry from outside the building to inside and from room to room in partition applications.*

# Building Components

## Windows

Windows are an integral part of any modular office design and the proper window system can help create a more open and engaging atmosphere, make spaces more environmentally friendly or add to aesthetics to the work space.



Windows can be made in a variety of sizes including our popular "Full-View" option.

### Standard Windows

These economical window styles include fixed windows that measure either 4' or 2' wide by 3' high and provide exceptional support and durability for industrial environments.

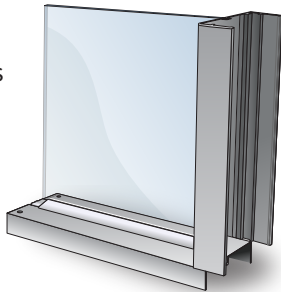

### Flush Windows

Our single flush window system provides a smooth surface without ledges on one side of the wall surface.

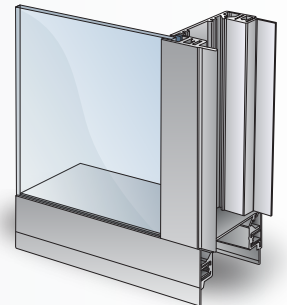

### Beveled Windows

Designed specifically for cleanroom applications, the angled style allows for easy cleaning and eliminates ledges that collect dust and particles.

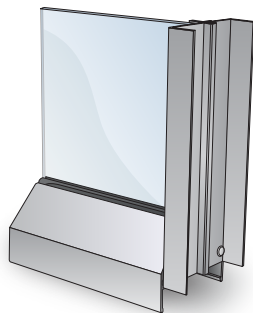

### Double Flush Windows

Ideal for interior wall applications requiring flush surfaces on both sides of the wall as in cGMP applications.

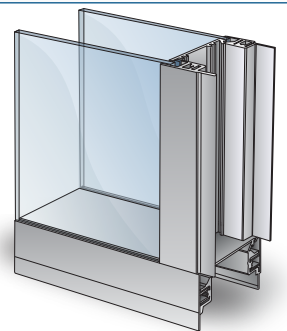

## Glazing Options

All standard windows feature 1/4" clear tempered safety glass, but we also offer several custom glazing options, including:

- Laminated glass for added sound control
- Insulated glass for better thermal insulation
- UV glass
- And much more



## Doors

Creating efficient and effective environments often requires the integration of special doors to facilitate entry and exit, streamline workflow or provide stricter control over air quality, temperature or humidity. Our engineers excel at integrating a wide variety of doors into our designs.



Standard Steel Doors



High Speed Roll-Up Doors



Impact Doors



Sliding Doors

### Standard Doors

Standard doors include 3070 x 1-3/4" and 6070 x 1-3/4" sizes in 18 gauge steel door frames. The door and frame are finished with a polyester baked enamel and come with 1-1/2 pairs of 4-1/2" x 4-1/2" mortised hinges and a strike plate pre-assembled in a wall panel. The door features a commercial quality ADA compliant lever lockset with a 2-3/4" back set and mortised face plate.

These doors can be outfitted with a standard 1/4" clear tempered safety glass window as well as custom glazing, door closers, aluminum thresholds, optional locksets, door louvers, panic hardware, kickplates, hinges, handles, and more.

### Specialty Doors

By combining PortaFab's innovative Post-and-Panel design with its rugged, load-bearing framing systems and experience in modular design, our engineers are able to effectively integrate all types of roll-up, swinging, sliding and other specialty doors into your new space.

### Cleanroom Doors

Creating highly controlled environments often requires the integration of sophisticated door systems. With extensive experience in modular cleanroom design, our designers can effectively integrate these complex door systems into your design. Cleanrooms can be constructed to include removable panel sections for equipment access.

# Building Components and Features

## Roof & Ceiling Options

PortaFab modular offices and enclosures utilize a 22 gauge ribbed steel roof, 1-1/2" deep, painted and cut to length. This "dust cover" is supported by the framing system and lies within the cornice mold or top cap of the office for a clean and professional look. Units over 12' in length require roof beams to support the dust cover.

The ceiling system hangs approximately 6" from the dust cover providing a plenum for electrical wiring and light fixtures. It consists of a prepainted metal grid with lay-in acoustical ceiling tiles made from class A non-combustible white fissured mineral board. Standard ceiling tiles are 2' x 4'. Custom ceilings are available.

Ceiling Suspended From Roof Deck

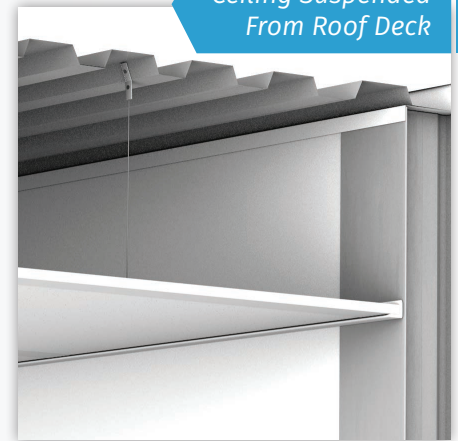

Load-Bearing Roof Beam

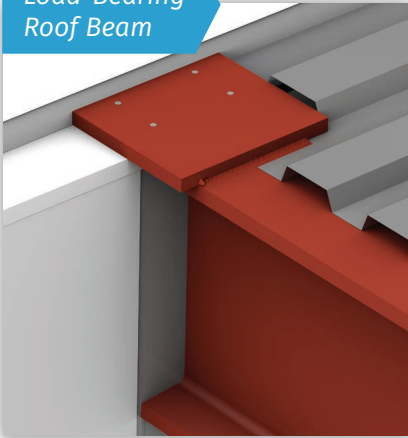

## Load Bearing Roofs

Floor space is an expensive and valuable commodity in any manufacturing facility or distribution center. In most cases the space in the high bay areas are never fully utilized thus forcing companies to expand outward with more square footage. Load-bearing platforms provide an economical solution to saving valuable floor space by going "up" and taking advantage of unused vertical space.

The stud posts in all of our wall systems are structurally designed to support up to 125 lbs./square foot - ideal for walkable platforms, maintenance loads, two story structures and even parts storage. In addition, we can provide a number of accessories to finish out the load bearing roof including: stairs and landings, handrail, swing gates and a variety of flat surfaces to finish off the top of the roof.

Dust Cover Support Beam

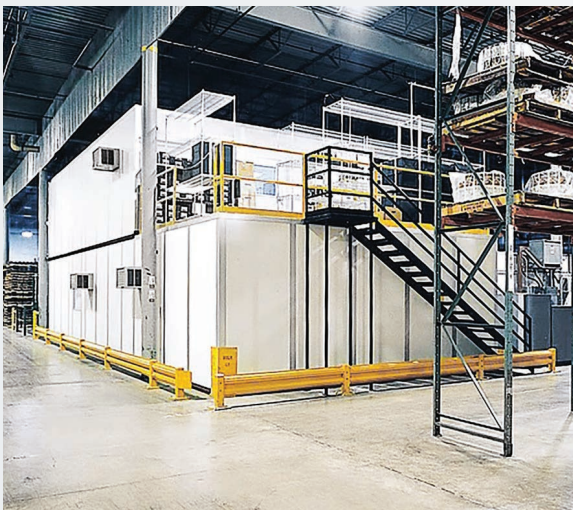

Load-bearing characteristics allow second stories for offices or storage.



# Modular Electric

For even greater convenience, offices can be outfitted with a pre-engineered modular wiring system. This system significantly reduces time and costs associated with new in-plant office installations by providing all the necessary electrical hardware in a convenient and pre-engineered “snap together” wiring system.

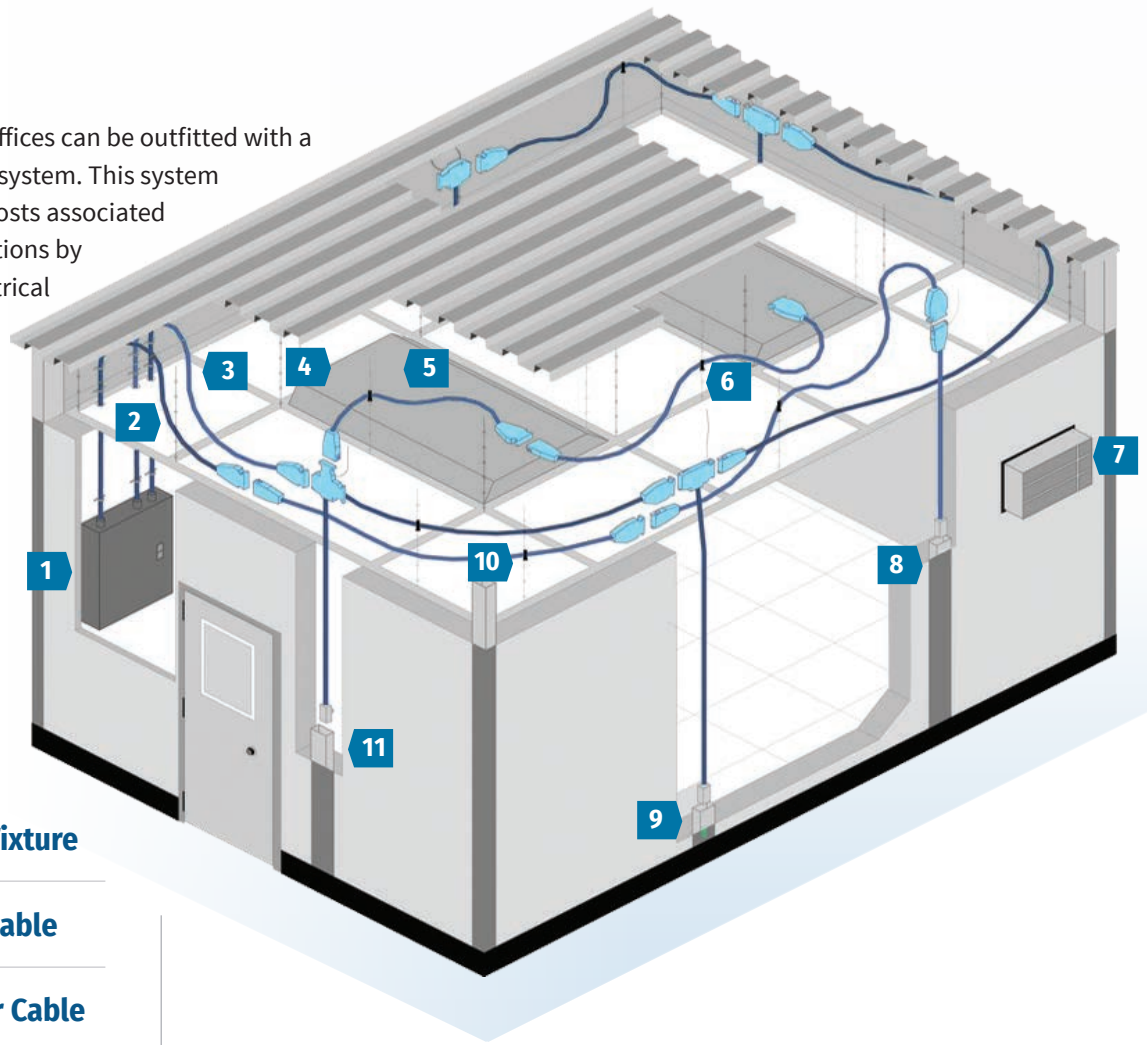

- 1** Circuit Breaker Box
- 2** 240v Converter Cable
- 3** 120v Converter Cable
- 4** 2' x 4' Recessed Light Fixture
- 5** 120v Lighting Fixture Cable
- 6** 120v Lighting Extender Cable
- 7** Modular Climate Control Unit
- 8** 240v Dedicated Receptacle Drop
- 9** 120v Duplex Receptacle Drop
- 10** 120v Extender Cable
- 11** 120v Switch Drop

## Climate and Environmental Control

PortaFab modular buildings can accommodate a wide variety of systems to control temperature, humidity and air quality. Small, inplant offices and booths are often outfitted with wall-mounted units while larger installations typically integrate with centralized HVAC systems.

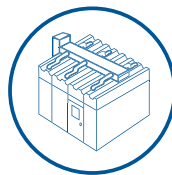

Integrated HVAC



Wall Unit

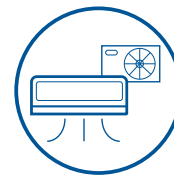

Ductless

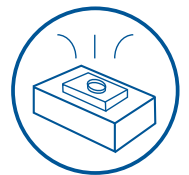

Fan Filter Unit

## Electrical

PortaFab modular buildings are designed to accommodate standard electrical components and fluorescent light fixtures. The OmniFlex, Series 300 and all PortaMax systems feature studs with wiring raceways that make installing electrical, voice, and data systems easy.

## Standard Components

Standard electrical and lighting components include 2' x 4' fluorescent lights with recessed troffers, outlets, switches and circuit breaker boxes. Optional electrical components available.



Removable cover plate for wiring access.



# Space Utilization

*The applications  
are endless...*

*Elevated Supervisor Office  
with Underneath Storage*



*Two-Story Administration Building*

*Two-Story Building with Printing  
Process & Office Space Above*







Two-Story Inplant Offices

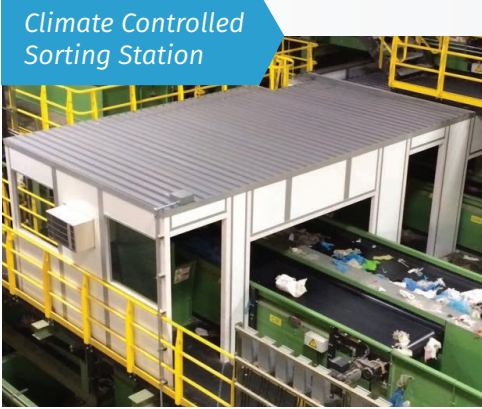

Climate Controlled Sorting Station



Electronic Assembly Area with Mezzanine



Inplant Office and Conference Rooms with Full-View Windows



Multilevel Structure with Integrated Material Lift



Two-Story Building with Loading Docks & Second Floor Offices



# Space Utilization

Test Area with Environmental Control



Offices on Mezzanine



Demising Wall with Standard Windows & Sliding Doors



Corporate Offices with Privacy Glass Windows



# Cleanrooms



Freestanding Cleanroom with HVAC

Cleanroom with Sliding Doors & Pass-Thru



Cleanroom for Medical Device Manufacturing



Injection Molding Room

Electronics Cleanroom with Raised Floors





# Environmental Control



Quality Assurance Lab



Medical Research Laboratory



Stand-Alone Cleanroom with Integrated HVAC and Filtration



CMM Room, QA/QC Lab and Office Space



Cleanroom with Removable Wall Section



University Research Facility





Demising Wall Separating Warehouse & Manufacturing



Environmentally Controlled Paint Finishing Enclosure



Thermally Controlled Lithium Battery Aging Enclosure

# PORTAFAB

Modular Building Systems



Environmentally Controlled Testing Center



Cultivation Rooms



# Environmental Control

Floor to Ceiling Food Process Enclosure



Clean Environment for Packaging



Environmentally Controlled Printing Enclosure

CMM Room



Cleanroom Labeling Area



# Specialty Applications

Restrooms



Simulation Test Chamber



Inplant Supervisor Office



Data Center Walls



Locker Rooms with Plumbing Chase

**PORTAFAB**  
Modular Building Systems



# Assorted Applications

Locker Rooms



Climate Controlled Test Facility with Top Hung Sliding Doors



Employee Breakroom





Temperature Control for Assembly Area



Laser Booth Enclosure

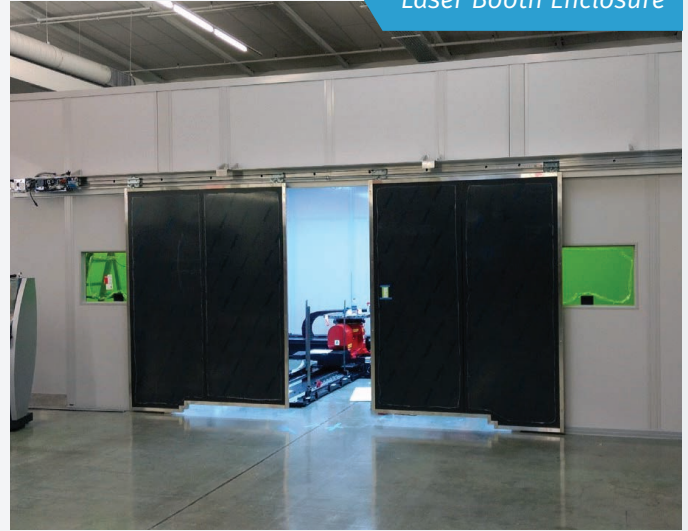

Test Labs



Two-Story Office Complex

Cleanrooms for University/Research Labs





# Assorted Applications

CMM Test Enclosure



Conference Room



Quality Inspection Lab with High Speed Roll-Up Door



Electronics Assembly Cleanroom



Food Processing Laboratory



Offices, Locker Rooms, & Restrooms



Exercise Training Center







Customized designs enable you to interface easily with M.E.P. and conveyers



**PORTAFAB**  
Modular Building Systems

Deployable Logistics Center



Punch Press & Lab Enclosure

# Additional Modular Construction Capabilities



## Painting and Finishing Systems



## Modular Architectural Cleanroom Systems



## Data Center Walls & Enclosures